

Lunch Bag

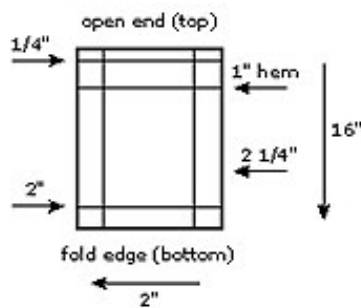

Fill with all kinds of goodies and have a healthy lunch!

Materials and Supplies

- Brother embroidery machine
- Canvas or duck fabric 12" X 32"
- Velcro 1"
- Stabilizer
- Hoop 5 X 7
- Embroidery thread

Level of Difficulty

Beginner

Cutting:

- Step 1** Mark fabric piece on both sides.
- Step 2** Embroider the design on one side of the folded piece between the 1" marks on the top and the 2" mark at the bottom of the fabric.
- Step 3** To form the bottom of the lunch bag, fold on the bottom folding wrong sides together. Fold each side back again on the 2" marked line with the right sides together forming a pleat. Stitch the side seams 1/4".
- Step 4** For the top hem, fold under 1/4" then fold over 1" and stitch. Turn the bag to the right side.
- Step 5** To make the fold lines on the bag, fold the bag on 2-1/4" mark line and use that line as a guide. Top stitch about 1/8" from the fold starting from one side of top around to the other side. Repeat with the other side. Sew Velcro at top inside for a closure.

Barbara Tucker
Brother International
Educator